



Chester and Midlothian Campuses

Post-Construction Stormwater Management Inspection & Maintenance Manual



June 2024

BCC - Midlothian Campus
800 Charter Colony Parkway
Midlothian, VA 23114

BCC - Chester Campus
13101 Jefferson Davis Hwy
Chester, VA 23831

For reporting pollution into stormwater runoff contact
the Director of Facilities and Safety at (804) 840-8354.

TABLE OF CONTENTS

1.0	INTRODUCTION AND PURPOSE	1
2.0	DOCUMENTATION REQUIREMENTS	2
2.1	Construction Record Drawings	2
2.2	BMP Inspection Forms	2
2.3	BMP Maintenance Follow-up Forms.....	3
2.4	Annual Reporting to DEQ	3
3.0	INSPECTION FREQUENCY	5
3.1	DEQ Stormwater Inspector Certification.....	5
4.0	STORMWATER MANAGEMENT FACILITIES	6
4.1	Retention	6
4.2	Detention.....	7
4.3	Vegetated Roof	7
4.4	Rainwater Harvesting.....	8
4.5	Dry Swale	8
4.6	Manufactured Filter Device “Filterra”	9
4.7	Manufactured Hydrodynamic Device “Continuous Deflector Separator”	9
5.0	BMP INSPECTION FORMS.....	10
5.1	Stormwater Management Facility Information.....	10
5.2	Inspection Elements.....	10
5.2.1	Contributing Drainage Area	10
5.2.2	Pretreatment	11
5.2.3	Inlets	11
5.2.4	Sediment Forebay	11
5.2.5	Vegetation	11
5.2.6	Emergency Spillway.....	11
5.2.7	BMP Outfall.....	12
5.2.8	Principle Spillway.....	12
5.2.9	Berm/Embankment.....	12
5.2.10	Low Flow Orifice.....	12
5.2.11	Miscellaneous	12
6.0	FACILITY MAINTENANCE	13
6.1	Routine Maintenance.....	13
6.2	Corrective Maintenance.....	13

APPENDICES

Appendix A: Stormwater Facility Inspection Forms

Appendix B: BMP Maintenance Follow-up Form

ACRONYMS

BCC	Brightpoint Community College
BMP	Best Management Practice
CH	Virginia BMP Clearinghouse
CPESC	Certified Professional in Erosion and Sediment Control
CWA	Clean Water Act
DEQ	Virginia Department of Environmental Quality
EPA	Environmental Protection Agency
IDDE	Illicit Discharge Detection and Elimination
MEP	Maximum Extent Practicable
MS4	Municipal Separate Storm Sewer System
NEPA	National Environmental Policy Act
NPDES	National Pollutant Discharge Elimination System
SWPPP	Stormwater Pollution Prevention Plan
TMDL	Total Maximum Daily Load
VPDES	Virginia Pollutant Discharge Elimination System
VSMP	Virginia Stormwater Management Program

1.0 INTRODUCTION AND PURPOSE

Land development disturbs stable vegetated landscapes and increases impervious areas, which in turn increases the stormwater runoff from the land surface. Development also increases pollutant concentrations in stormwater runoff, as pollution associated with development is deposited onto hardened surfaces and carried by runoff into nearby water bodies. Such pollutants include sediment, suspended solids, nutrients, pesticides, herbicides, heavy metals, chlorides, hydrocarbons, other organics, and bacteria. To remove pollutants from stormwater runoff, structures are installed to reduce the pollutant loads using various processes. These stormwater structures are called Best Management Practices, commonly referred to as BMPs. They are designed to reduce flooding, remove pollutants, and decrease the amount of stormwater runoff that ultimately flows into our creeks, streams, and rivers. Ensuring these BMP facilities function correctly requires long-term inspections and maintenance.

This manual presents the standard protocol for Post-Construction Stormwater Management Inspection and Maintenance procedures and satisfies the written procedures for long-term operation & maintenance (O&M) requirements of the small municipal separate storm sewer system (MS4) General Permit. As a regulated MS4, Brightpoint Community College (BCC) is obligated to meet the requirements of the MS4 General Permit (General Permit). The General Permit is issued through the Virginia Pollutant Discharge Elimination System (VPDES), which is administered at the state level by the Virginia Department of Environmental Quality (DEQ). The MS4 program is part of the Federal National Pollutant Discharge Elimination System (NPDES), which is authorized through the Clean Water Act and regulated through the US Environmental Protection Agency (EPA).

BCC's Post-Construction Stormwater Management Program, which is a series of written procedures in this manual, ensures adequate long-term operation and maintenance of BMPs for BCC. BCC may use inspection and maintenance specifications available from the Virginia Stormwater BMP Clearinghouse or inspection and maintenance plans developed in accordance with the department's Stormwater Local Assistance Fund (SLAF) guidelines.

BCC's Post-Construction Stormwater Management Program includes three distinct components:

- **Documentation** – Procedures to document efforts related to the Post-Construction Stormwater Management inspection and maintenance procedures are outlined in Section 2.0 of this manual.
- **Inspections** – Discussion of Post-Construction Stormwater Management facility types and components that require inspections are outlined in Section 4.0 of this manual. Instruction for the Post-Construction Stormwater Management Facility inspections are outlined in Section 5.0 of this manual. Stormwater facility inspection forms are provided in the Appendices.
- **Maintenance** – Discussion of typical maintenance requirements are provided in Section 6.0 of this manual.

2.0 DOCUMENTATION REQUIREMENTS

Documentation of Post-Construction Stormwater Management efforts is critical for demonstrating compliance with the General Permit. All documentation related to Post-Construction Stormwater Management is required to be maintained on file and available upon request and include:

- Project Records, including stormwater plans (retain for 3 years);
- Construction Record Drawings (as-builts retain in perpetuity or until the BMP is removed);
- Completed BMP Inspection Forms (retain for 5 years); and
- Completed BMP Maintenance Follow-up Forms, when applicable (retain for 5 years).

2.1 Construction Record Drawings

Upon completion of the construction of a stormwater BMP, a record drawing should be obtained. The record drawing, or as-built, serves the purpose of:

- Ensuring the BMP was built per the design plans and
- As a reference over time to assist with long-term inspection and maintenance.

Ideally, the record drawing would also prescribe inspection frequency and discuss critical maintenance needs. Information such as the design of the outfall structure, elevations, and vegetation plans will allow BCC to restore the BMP to its original design, when necessary. Sometimes an issue with a BMP may not be evident during an inspection, such as if the facility should be holding water or be dry. A record drawing can be referenced to make that determination. Examples include discovering the surface of an infiltration basin or a low-flow orifice being clogged, resulting in ponding. The intended function, such as time for water to drawdown out of the basin, may not be known until the record drawing is reviewed.

In some cases, especially with older facilities, a record drawing may not be available. In these cases, the Virginia BMP Clearinghouse can be referenced for additional information regarding inspections and maintenance of each type of stormwater BMP. The Clearinghouse can be found at:

<https://www.swbmp.vwrrc.vt.edu/>

2.2 BMP Inspection Forms

The General Permit requires BMPs be inspected at a minimum once per year by BCC. Completion of comprehensive inspection forms assists the inspector to:

- Inspect each critical component of the facility;
- Identify maintenance needs; and
- Properly document inspections to demonstrate compliance with the General Permit.

BMP inspection forms in Appendix A have been developed to assist the inspector, and unique forms are provided dependent on the type of BMP being inspected. In addition to the completion of the inspection forms, where applicable, a BMP Maintenance Follow-up Form should be completed as described in the next Section. Inspection forms are discussed in additional detail in Section 5.0 of this Manual.

2.3 BMP Maintenance Follow-up Forms

In the case that issues are identified on BMP Inspection Forms, it is important to ensure the necessary maintenance is performed in a timely manner. It is critical that documentation demonstrating the completion of the maintenance is maintained on file to demonstrate compliance. This documentation should be provided on the BMP Maintenance Follow-up Form in Appendix B. This Manual establishes time frames for completing maintenance needs identified during inspections. Time frames shall be designated by the Director of Facilities and Safety, or designee, and be prioritized based on the nature of the maintenance need. High prioritization should be given to situations that include issues with:

- BMP functionality regarding the potential to cause flooding (e.g., structural integrity of the embankment or clogged outflow structures);
- BMP functionality regarding the inability to remove pollutants as designed (e.g., clogged infiltration surface, dead vegetation); or
- BMP acting as a source of sediment (exposed soils requiring stabilization).

In the case of corrective maintenance, as identified in Section 6.2, a timeframe designation should be carefully considered by the Director of Facilities and Safety. In some cases, repairs may be necessary as soon as possible.

The Maintenance Follow-up Form is separated into two sections. The first section should be completed by the individual performing the BMP inspection. This section identifies the BMP, the inspection form on which an issue is identified, a description of the necessary maintenance, and an indicator of the severity of the issue(s) identified. The second section of the form is completed by the BCC Director of Facilities and Safety and identifies who will perform the maintenance, sets a timeframe for performing the maintenance, and includes a description of the completed maintenance.

2.4 Annual Reporting to DEQ

BCC must annually report to the DEQ information pertaining to its Post-Construction Stormwater Management efforts. By October 1 of each year BCC shall electronically report new BMPs implemented and inspected as applicable between July 1 and June 30 and newly discovered BMPs previously not reported using the DEQ BMP Warehouse. BCC shall use the associated reporting template for stormwater management facilities not reported, including:

- Stormwater management facilities installed to control post-development stormwater runoff from land disturbing activities less than one acre in accordance with the Chesapeake Bay Preservation Area Designation and Management Regulations 9VAC25-830, if applicable, and for which a General VPDES Permit for Discharges of Stormwater from Construction Activities was not required.
- Implemented as part of a TMDL action plan to achieve nitrogen, phosphorus, and total suspended solids reductions.
- Any BMPs that were not reported in accordance with the first two bullets.

Reporting requirements include the submittal of BCC's Post-Construction Stormwater Management BMP electronic database into the DEQ BMP Warehouse that includes the following information:

- The BMP type;
- The BMP location as decimal degree latitude and longitude;
- The acres treated by the BMP, including total acres and impervious acres;
- The date the BMP was brought online (MM/YYYY). If the date brought online is not known, the permittee shall use 06/2005;
- The 6th Order Hydrologic Unit Code in which the BMP is located;
- Whether the BMP is owned or operated by the permittee or privately owned;
- Whether or not the BMP is part of the permittee's Chesapeake Bay TMDL action plan required in Part II A or local TMDL action plan required in Part II B, or both;
- If the BMP is privately owned, whether a maintenance agreement exists;
- The date of the permittee's most recent inspection of the BMP; and
- Any other information specific to the BMP type required by the DEQ BMP Warehouse (e.g., linear feet of stream restoration).

BCC shall include in the annual report the following information:

- Total number of inspections conducted on stormwater management facilities owned or operated by BCC;
- A description of the significant maintenance, repair, or retrofit activities performed on the stormwater management facilities owned or operated by the permittee to ensure it continues to perform as designed. This does not include routine activities such as grass mowing or trash collection;
- A confirmation statement that BCC electronically reported stormwater management facilities using the DEQ BMP Warehouse in accordance with the MS4 General Permit.

3.0 INSPECTION FREQUENCY

The General Permit requires inspection of all stormwater management facilities at a minimum of once per year. In addition to the annual inspections, the Virginia Stormwater Management Program and regulations require a stormwater facility inspection after any storm event that exceeds the principal spillway, or more specifically, whenever the emergency spillway is engaged in accordance with the VSMP Regulations 9VAC25-870-200.

Further, the inspection frequency may vary for a specific BMP if additional inspections are prescribed on the construction record drawings. This is oftentimes the case for the first year of a newly constructed BMP to ensure stabilization takes hold and any necessary plants survive.

3.1 DEQ Stormwater Inspector Certification

Individuals performing inspections of stormwater management facilities for BCC are required to maintain a Stormwater Inspector Certification from DEQ. Information regarding the certification requirements is available at the DEQ Stormwater Certification webpage.

4.0 STORMWATER MANAGEMENT FACILITIES

This section describes the types of BMPs found on the BCC campuses and their general layout and function. If additional BMPs are added to the campuses that differ in type, the manual will require updates to assist with compliance in accordance with Section 2.4 of this manual. Updates should be incorporated into the Manual within 1 year of the installation of the new BMP type.

There are several types of BMPs on the BCC campuses. A discussion of the facility types is included in the following sections.

4.1 Retention

These basins have at least one inflow channel, an embankment/dam, typically a riser in the basin although not always, a principal spillway structure to route the drainage through the embankment, and an outlet structure. Wet ponds consist of a permanent pool of standing water that promotes pollution removal and reduces flooding. Retention basins can also be dry facilities which would mimic the dry detention schematic. Runoff from each storm enters the pond and raises the normal water level, and the outlet structure releases the drainage at a slower rate over a longer period of time. This “draw down” or holding time allows pollutants to settle out of the stormwater and lessens the impact of the flow volume on the outlet channel.

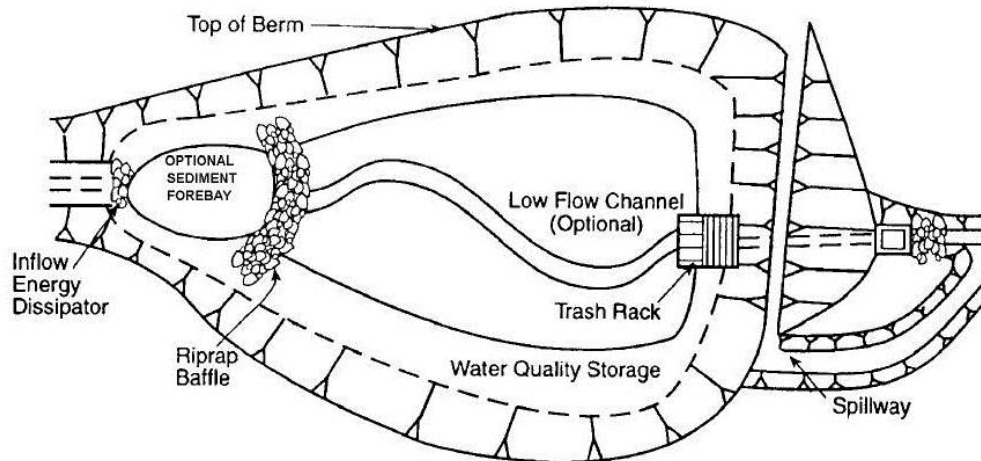

Figure 1: Typical Retention Facility Plan

4.2 Detention

These basins have at least one inflow channel, an embankment/dam, a bottom level orifice, sometimes a riser in the basin, a principal spillway structure to route drainage through the dam, and an outlet structure. These basins do not have a normal pool and remain dry except during and shortly after storm events. Some extended detention facilities may have a wet marsh with plantings in the bottom for additional pollutant removal. On rare occasions the extended detention basin may be designed to have a wet normal pool. If a plan does not indicate a wet marsh or normal pool elevation, investigate to ensure a constant pool of water is not due to blockage.

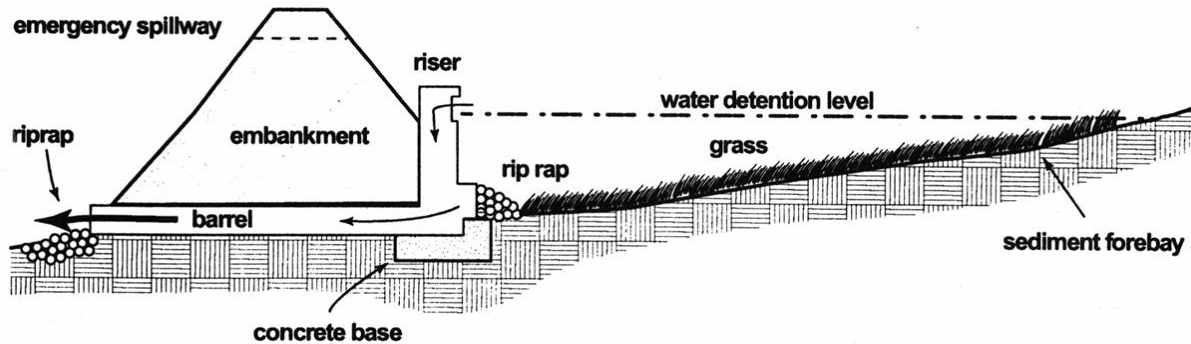

Figure 2: Typical Dry Detention Basin Section

4.3 Vegetated Roof

Vegetated roofs (or green roofs) are systems designed to capture and temporarily store stormwater runoff in the growing media before it is conveyed into the storm drain system. A portion of the stormwater either evaporates or is taken up by the plants, which helps reduce peak runoff volumes, peak runoff rates, and pollutant loads. The planting media is typically 2 to 6 inches thick, which is planted with drought tolerant species. Underneath is a root barrier, insulation layer, and a waterproof membrane above the roof deck material. Horizontal channels may also convey water to outlets that connect to pervious areas near the building or directly to the storm drain.

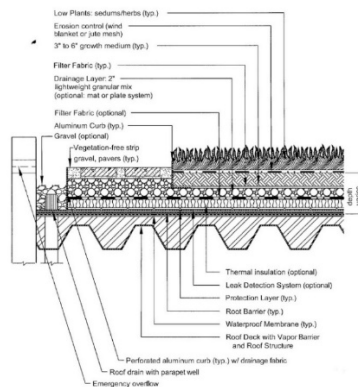

Figure 3: Typical Vegetated Roof Section

4.4 Rainwater Harvesting

Rainfall can be captured to use for a variety of purposes, including irrigation, vehicle washing, toilet flushing, fire suppression, and even to provide potable water, if the water is appropriately purified. Over time, the cost savings from not having to purchase municipally treated water for these purposes can defray the cost of the harvesting system. Rainwater harvesting system runoff volume reduction rates are user defined, based on cistern/tank size, configuration, and demand drawdown. They can be combined with a variety of downgradient runoff reduction practices, including swales, infiltration, and bioretention. Rainwater harvesting systems have six main components: roof surface, collection and conveyance system, pre-screening and first flush diverters, storage tank (cistern or rain tank), distribution system, and overflow/filter path/secondary runoff reduction/treatment practices.

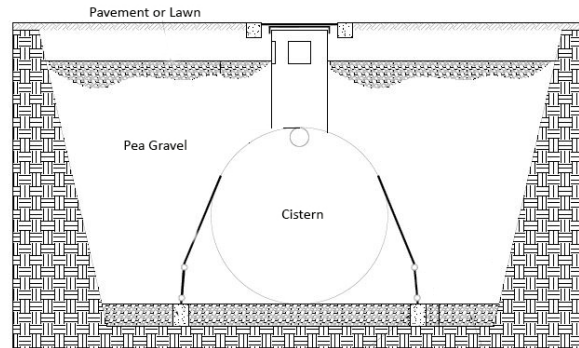

Figure 4: Typical Rainwater Harvesting Section

4.5 Dry Swale

Dry swales are shallow, linear channels that function as a bioretention facility. A dry swale system temporarily stores and filters runoff by infiltration through special soil media and often into an underdrain which conveys the treated runoff to a conveyance system. Dry swales can either be covered with turf alone or planted with tall meadow grasses, decorative herbaceous cover, or trees.

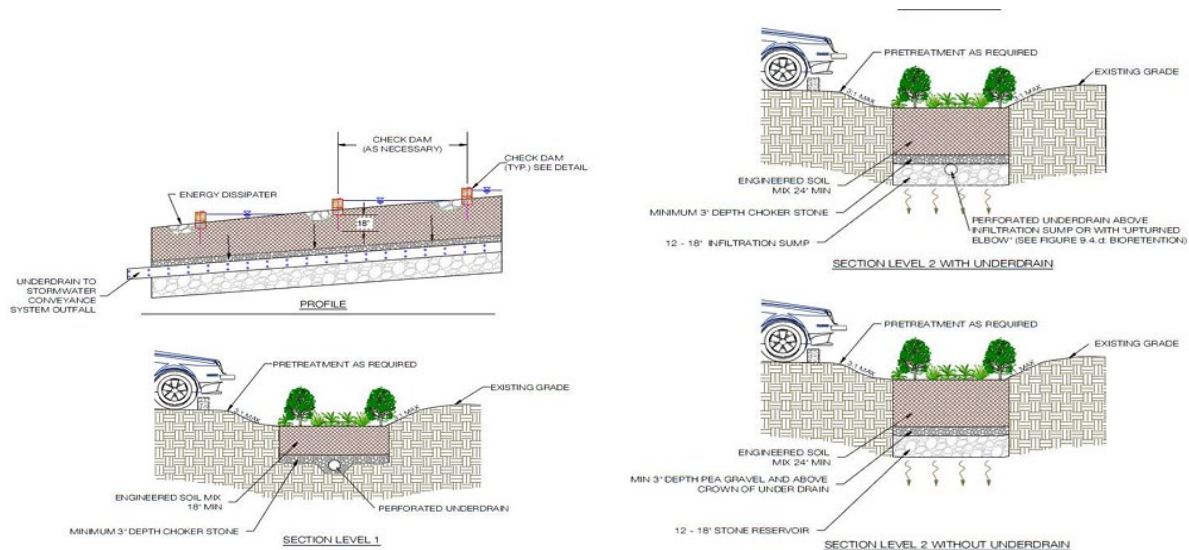

Figure 5: Typical Dry Swale Details

4.6 Manufactured Filter Device “Filterra”

A Filterra is a proprietary system similar to a bioretention facility in its function and application but has been optimized for high volume/flow treatment and high pollutant removal. Filterras are comprised of engineered biofiltration media and a plant that work together to remove pollutants typically found in urban stormwater runoff. The system is a fully equipped, pre-constructed, drop-in place unit designed for applications in the urban landscape to treat contaminated runoff from impervious surfaces.

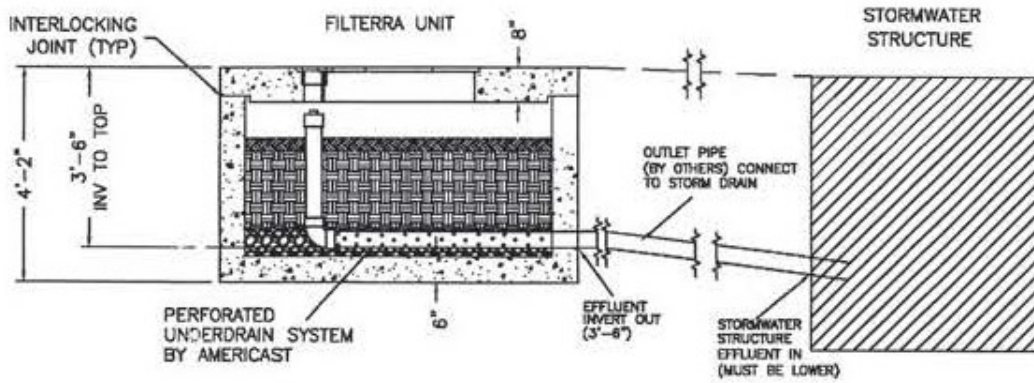

Figure 6: Typical Filterra Section

4.7 Manufactured Hydrodynamic Device “Continuous Deflector Separator”

A Continuous Deflector Separator is a proprietary system that guides stormwater into a separation chamber where water velocities create a swirling vortex. The swirling vortex forces floatables and solids to the center of the separation chamber and sediment settles into an isolated sump. All pollutants remain in these sections of the unit until removed during maintenance. Treated water exits the system.

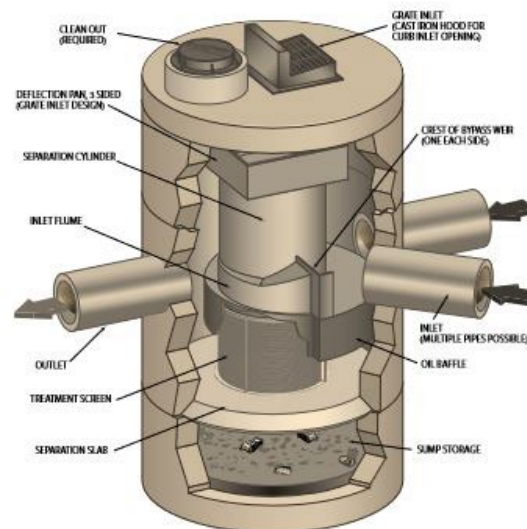

Figure 7: Typical CDS Schematic

5.0 BMP INSPECTION FORMS

BMP inspection forms are an integral part of the Post-Construction Stormwater Management Program and provide documentation to demonstrate compliance to the General Permit requirements. The following sections are intended to provide guidance when completing the BMP inspection forms located in Appendix A.

5.1 Stormwater Management Facility Information

The following describes the general information required on the BMP inspection form:

- “Owner”: BCC;
- “Facility ID #”: This is the facility identification # as identified on the IDDE & Post-Construction Stormwater Facility Map (incorporated by reference);
- “Inspection Date”: The date the inspection is taking place;
- “As-Built Plans Available”: Are the original As-Built plans available for reference? Indicate yes or no;
- “Date of Last Inspection”: The date of the last inspection of the facility. This information should be maintained on file and in the BMP inventory database;
- “Inspector(s)”: The name of the inspector performing the inspection;
- Determination if maintenance was required and performed that stemmed from a previous inspection. The inspector should be able to obtain and review the previous inspection form. During the current inspection, the inspector should be able to determine if previous maintenance items have been addressed; and
- Determination if maintenance is needed based on the current inspection. Maintenance would typically be required if “Yes” is selected for any of the issues on the form. In this case, a BMP Maintenance Follow-up Form should be submitted to the Director of Facilities and Safety.

5.2 Inspection Elements

The inspection form is designed so that individual elements of the stormwater facility are inspected for the occurrence of typical issues. For each element issue, the inspector indicates a “yes,” “no,” or “N/A.” Where “yes” is indicated, the corresponding corrective action identified on the form needs to be scheduled. Proper evaluation of element issues is critical to identify maintenance needs; and therefore, preserve proper functionality of the BMP. The notes section of the form can be utilized to indicate the severity of maintenance needs. The following sections define and describe each component of the Inspection Form.

5.2.1 Contributing Drainage Area

The contributing drainage area includes any area that drains to the facility, both onsite and offsite. These areas should be examined as a potential source of trash, debris, or erosion if any of these are within the facility. Eliminating the source of the issue is essential and works as a preventative measure to ensure long term functionality of the BMP.

5.2.2 Pretreatment

Pretreatment is the initial structure or measure through which stormwater runoff is routed before it enters the BMP. It serves as a preliminary filter, or trap, to remove silt and sediment that could reduce the pollutant removal efficiency of the BMP. As a result, the pretreatment structures or measures require cleaning out more often than the facility itself. If there are significant amounts of sediment in the pretreatment structure, it should be removed to maintain its function and to prevent the sediment from being re-suspended in runoff and conveyed to the BMP and subsequently downstream to the receiving waters.

5.2.3 Inlets

Inlets, such as drop inlets and curb inlets, route runoff through the storm sewer and into BMPs for treatment from the contributing drainage area. The inspector should determine if sediment, trash, or other obstructions are preventing flow from being conveyed to the BMP.

5.2.4 Sediment Forebay

A sediment forebay is a pretreatment structure that traps debris, trash, sediment, and other pollutants from entering the BMP. Sediment must be cleaned out once the level in the forebay reaches 50% of the capacity. This can be measured by placing a marked stake in the forebay with the marking indicating the 50% level. The marker is useful since the forebay may often maintain a wet pool. Excessive sediment accumulation may also indicate exposed soils within the drainage area to the BMP that require stabilization.

5.2.5 Vegetation

For certain BMPs, such as constructed wetlands, the planting plan serves as a component of the design. Vegetation assists with filtering and biological uptake of pollutants, and maintaining the plantings is critical to ensure functionality. The BMP vegetation should match the design plans for the number and species of plants present. Having more plants than is shown on the plans is acceptable as long as it is not an invasive species and/or the overgrowth is not impacting the storage volume and the BMP's ability to drain. Mosquito breeding can also be a concern, especially once cattail matting has become established in the BMP. Therefore, cattails are not a desirable species within a BMP. Considering the general planting location in the facility is also helpful. For example, if there is a section of plants adjacent to a road shoulder that is dying, it may be indicative of contaminated runoff, such as from de-icing operations. Vegetation should be replaced in accordance with the approved plans, acceptable species, and quantities from the Virginia BMP Clearinghouse for the BMP type, or as specified by a licensed Landscape Architect or Professional Engineer.

5.2.6 Emergency Spillway

The emergency spillway is a channel that conveys stormwater during large storm events from the BMP to an outfall, usually the same one as the principal spillway or main outlet. It prevents the facility from overtopping during large storm events. Not all facilities have an emergency spillway. Spillways can be lined with various materials including grass with or without erosion control matting, riprap, or concrete, based on the velocity of flows predicted through the spillway. The spillway is usually visible as a low spot a minimum of 1' below the top of embankment off to one side. Consult the design plans for additional details.

5.2.7 BMP Outfall

The BMP outfall is the location where flows are discharged from the BMP. The BMP outfall should discharge into a stabilized receiving channel. At the location where the discharge from the BMP enters the receiving channel, there is typically a riprap stone lining to prevent erosion, otherwise known as outlet protection. The purpose of many stormwater facilities is to protect the downstream channels, and thus, an evaluation of the outfall and the channel immediately downstream should be conducted to determine if erosion is occurring.

5.2.8 Principle Spillway

The principal spillway is the structure that controls how much flow exits the BMP during more frequent storm events. Flows typically pass through the control structure (e.g., orifice, riser) and subsequently through a culvert that passes through an embankment, if present. The principal spillway is used in most storm events, unlike the emergency spillway, which is only used during very large events. Because this is typically the only conveyance through the embankment, the functionality and structural integrity of the principal spillway is critical. Often, a riser may serve as the principal spillway and connect the discharge culvert to convey flows to the BMP outfall. The riser usually has a small opening, or orifice, that controls the amount of flow through the system. The functionality of the riser can have a large impact on the water level in the basin; and therefore, whether the designed pollutant removal is met. Larger storms may spill over the top of the riser through a grate. Inspections should ensure the top of the riser is free from obstruction as well as any orifices in the structure. Damage or deterioration can take the form of rust, cracking, exposed rebar, or additional holes in the structure.

5.2.9 Berm/Embankment

The embankment or berm is the fill section that detains runoff within the facility. The face of the dam is the front side that interacts with the water level and the top, or crown, is the highest flat surface. The downstream side is the back of the dam from the top down to where the fill section meets the natural grade (called the “toe” of the dam), typically just below the outfall. The face of the dam can potentially be a problematic area because of water pressure on and saturation through the embankment. Trees should not be allowed to grow in the embankment since their root systems can affect the structural integrity of the embankment. Roadways are not typically considered embankments because they have culvert pipes through them to convey stormwater effectively. Issues with the embankment can be critical to the function of the facility, downstream safety, as well as environmental concerns in the case of a failure.

5.2.10 Low Flow Orifice

The low flow orifice is the smaller outflow hole, usually in the riser, that slows the discharge from the pond, protecting against downstream erosion. It also provides settling time for the runoff within the facility. The low flow orifice tends to clog because of its small size and will typically have a trash rack or screen on the front of it.

5.2.11 Miscellaneous

This section captures any other pertinent features or issues of the facility not otherwise addressed in the checklist. Issues may be identified in the footprint area and with general issues such as difficulty in accessing the BMP. Note any of the criteria needing repair and include applicable location information for reporting.

6.0 FACILITY MAINTENANCE

The effectiveness of post-construction stormwater control BMPs depends upon regular inspections and maintenance of all aspects of the facility. There are typically two types of BMP maintenance, referred to as routine maintenance and corrective maintenance.

6.1 Routine Maintenance

Routine maintenance consists of preventative measures that are essential to the ongoing care and upkeep of a BMP. These measures are performed regularly to ensure proper function. Additionally, it helps prevent potential nuisances (odors, mosquitoes, weeds, etc.), reduces the need for corrective maintenance, and reduces the chance of polluting stormwater runoff by identifying and repairing problems before they further deteriorate. Upon being identified during an inspection, routine maintenance should be conducted within six (6) months of the inspection.

Examples of routine maintenance include:

- Removal of any accumulated sediment from the forebays;
- Replacement of plants called for in the approved plans that have died or are diseased;
- Repair of the stormwater structures for erosion or undercutting;
- Repair of any erosion in the facility, including sloughing, animal burrows, and slopes;
- Repair of any deterioration at the outfall of the facility, including the riprap outlet protection;
- Removal of blockages from all trash racks, inlets, and outlets;
- Maintenance of adequate access to the facility and removal of woody vegetation as needed;
- Removal of trees from embankments;
- Exercise of valves to prevent them from locking up where applicable; or
- Removal all trash, debris, and floatables periodically from the facility.

6.2 Corrective Maintenance

Corrective maintenance is any maintenance that should be addressed for the facility to properly function in accordance with the plans. These items require more intensive repair efforts and should be addressed as a higher priority than routine maintenance. If there are structural deficiencies, or issues that raise the water level in the facility beyond the design intentions, corrective maintenance is required and should be conducted as soon as possible to prevent downstream damage to properties and/or the environment. Upon being identified during an inspection, corrective maintenance should be conducted within one (1) year of the inspection contingent on complexity. Reasonable progress steps should at least be taken.

Examples of Corrective Maintenance include:

- Repair of any deterioration or issues with the principal spillway and riser, such as evidence of spalling, joint failure, leakage, corrosion, etc.;
- Extensive sediment removal when inspections indicate that 50% of the forebay sediment storage capacity has been filled;
- Control or removal of invasive species and plant growth if there are impacts to the storage volume (i.e., water levels rise because the vegetation is taking up the water storage space); or
- Removal of woody vegetation from the embankment, if present, to prevent structural damage.

Further information on maintenance recommendations for various types of BMPs can be found on the Virginia BMP Clearinghouse at: <https://swbmp.vwrrc.vt.edu/>

Appendix A: Stormwater Facility Inspection Forms

BMP Operation & Maintenance Inspection for Dry Swale

Owner Name:	Facility ID # (See Mapping):
Date of Inspection:	As-built plans available: Y N
Date of Last Inspection:	Inspector:
Were issues identified during the previous inspection that required maintenance?	Y N
If so, was the maintenance performed and recorded on a BMP Maintenance Follow-up Form?	Y N
If no, explain:	
Does the current inspection, as summarized hereon, identified maintenance needs?	Y N
If yes, please complete a BMP Maintenance Follow-up Form and provide to the Director of Facilities upon completion.	

BMP Element	Problem	Yes	No	N/A	Corrective Action
Contributing Drainage Area	Excessive trash/debris				Remove trash/debris and properly dispose of.
	Bare exposed soil				Stabilize with seed and mulch. E&S measures may be warranted until the area is stabilized.
	Evidence of erosion				Backfill area, seed, mulch and consider matting. E&S measures may be warranted until stabilization.
	Excessive landscape waste/yard clippings				Remove landscape waste and yard clippings to prevent clogging and properly dispose of them.
Pretreatment (if applicable) & Inlets	Excessive trash/debris/sediment				Remove trash/debris/sediment and properly dispose of.
	Evidence of clogging				Rake material to determine level of clogging, removed clogged material and replace with clean material per the plan specifications.
	Dead vegetation, exposed soil				Replace vegetation and stabilize with seed and mulch according to plans. E&S measures may be warranted until area is stabilized.
	Evidence of erosion				Backfill area, seed, mulch and consider matting, E&S Measures may be warranted until stabilized.
	Evidence of ponding, noticeable odors, water stains, presence of algae or floating aquatic vegetation				Determine source of issue and remove/repair it. Consult management and the IDDE manual as needed.
	Inlets provide inadequate conveyance into facility				Repair inlets to drain to facility per plans.
	Presence of invasive species/weeds				Remove invasive species/weeds
Underdrain/pea gravel filter	Perforated pipe is not delivering conveyances as designed				Check if pipe is clogged with debris or woody root punctures. Manually clear out or replace pipe immediately.
	Evidence of standing water. Does not dewater between storms. Water ponds on the surface of basin for more than 48 hours after an event				This is an indication that underlying soil interface is clogged. This should be promptly investigated and addressed.
	Evidence of blockage				Determine source of blockage and promptly remove and dispose of.
	Litter is present within the practice				Remove immediately. Maintain contributing areas free of litter.

Outlet/ overflow spillway	Filter media is too low, compacted, or inconsistent with design specifications.			Consult an engineer or approved plans for the proper media mix specifications and placement guidance for repairs.
	Mulch is older than 3 years or in poor condition			Mulch shall be removed and replaced every 2-3 years.
Filter media	Chemicals, fertilizer and/or oil are present			No dumping of yard wastes into practice. Remove oil/grease from practice immediately and consult the IDDE Manual.
	Sediments are greater than 20% of design depth			Check plant health, manually remove sediment immediately without damaging plants.
	Exposed/bare soil			Stabilize with seed and mulch. E&S measures may be warranted until stabilization.
	Filter bed is blocked and/or filled inappropriately			Check blockage level by raking the layer and check the deposit depth. Consult the approved plan specifications and/or an engineer.
	Outlets provide inadequate conveyance out of facility			Repair conveyance. Consult engineering as needed.
	Excessive trash/debris/sediment accumulation at inlet			Remove trash/debris/sediment and properly dispose of.
	Evidence of erosion at/around inlet			Repair erosion and stabilize - consider matting.
	Maintenance access to facility in need of repair			Restore access for inspections and construction maintenance equipment.
Outlet	Access road needs maintenance to convey construction maintenance equipment.			Restore access for inspections and construction maintenance equipment.
	Structural components in need of repair			Consult Engineer and approved design plans.
	Hydraulic control components in need of repair			Consult Engineer and approved design plans.
Overall	Excessive trash/debris/sediment			Remove trash/debris/sediment and properly dispose of.
	Evidence of erosion			Backfill area, seed and mulch -consider matting, E&S Measures may be warranted until stabilized.
	Evidence of oil/chemical accumulation, odor, algae or color.			Report to management and consult IDDE manual.
	Encroachment on facility by buildings or other structures			Contact Facilities Planning
	Additional Notes:			

Warning: If any facility component has a watertight cover—be careful regarding the possibility of flammable gasses within the facility. Care should be taken lighting a match or smoking while inspecting facilities that are not vented. If the facility is in a completely enclosed vault the OSHA Confined Space Entry procedures must be followed.

Note: A customized maintenance schedule must be prepared for each facility, since the maintenance tasks will differ depending on the scale of facility, the landscaping template chosen, and the nature of the surface cover. The above is a general guideline only.

BMP Operation & Maintenance Inspection for Detention, Retention and Extended Detention Basins

Owner Name:	Facility ID # (See Mapping):
Date of Inspection:	As-built plans available: Y N
Date of Last Inspection:	Inspector:
Were issues identified during the previous inspection that required maintenance?	Y N
If so, was the maintenance performed and recorded on a BMP Maintenance Follow-up Form?	Y N
If no, explain:	
Does the current inspection, as summarized hereon, identified maintenance needs?	Y N
If yes, please complete a BMP Maintenance Follow-up Form and provide to the Director of Facilities upon completion.	

BMP Element	Issue	Yes	No	N/A	Corrective Action
Contributing Drainage Area	Excessive trash/debris				Remove trash/debris and properly dispose.
	Bare exposed soil				Stabilize with seed and mulch. E&S measures may be warranted until stabilized.
	Evidence of erosion				Backfill area, seed, mulch and consider matting. E&S measures may be warranted until stabilized.
	Excessive landscape waste/yard clippings				Remove landscape waste and yard clippings to prevent clogging and properly dispose of them.
Pretreatment / Forebay / Inflow	Excessive trash/debris/sediment or other blockage				Remove trash/debris/sediment or blockages and properly dispose of.
	Dead vegetation, exposed soil				Replace vegetation and stabilize according to plans. E&S measures may be warranted until stabilized.
	Evidence of erosion, undercutting, or bare soils				Backfill area, seed, mulch and consider matting, E&S measures may be warranted until stabilized.
	Structural deterioration of inlets, outfalls or pretreatment overflow weirs into the facility				Repair and restabilize area. Consult plans for approved configuration or an engineer. E&S measures may be warranted until stabilized.
	Animal burrows				Fill in immediately and stabilize.
Aquatic Bench / Vegetation	Plantings inconsistent with approved plans.				Consult approved plans and/or management to ensure no approved plant substitutions were used. Remove unapproved plants and replace any required plantings in kind.
	Dead vegetation/exposed soil				Replace vegetation and stabilize according to plans. E&S measures may be warranted until stabilized.
	Invasive plants, such as cattails and phragmites, exceeds 15% of the planted area.				Invasive plants should be removed immediately. Vegetation may require periodic harvesting for proper long term management.

Berm/ Embankment	Overgrown, including woody growth 5' beyond the outfall pipe and/or embankment.			Removal of woody species near or on the embankment is critical for proper function and long term stability. Remove all woody growth including stumps. Consult an engineer for backfill specifications. Mow thick growth.
	There is sparse vegetative cover and erosion channels are present.			Backfill area with structural fill and consult engineer for proper specifications. Stabilize with seed and mulch, consider matting. E&S measures may be warranted until stabilized.
	Cracking, bulging, sloughing and seepage			Consult an engineer immediately to prevent failure.
	Evidence of animal burrows.			Fill in immediately and stabilize.
Riser	Structural condition of the riser is deteriorating.			Consult an engineer to recommend a repair and review the approved plans.
	Adjustable control valve inaccessible and inoperable (if present).			Repair valve to be operational.
	Pieces of the riser are broken or missing.			Repair immediately in accordance with the approved plans. Consult an engineer as needed.
	Riser or low flow orifice is blocked.			Remove blockage and properly dispose of.
	Riser provides inadequate conveyance out of facility.			Repair to properly convey drainage to the outfall per the approved plan. Consult an engineer as needed.
	Evidence of erosion or undermining at/around riser.			Repair erosion. Consult engineer for structural repairs as needed.
	Structural deterioration			Consult engineer for proper repair procedures.
Outlet / Outfall	Exposed rebar, joint failure, loss of joint material, misalignment, leaking or corrosion			Repair concrete to cover rebar. Consult engineer for all other structural repairs.
	Excessive trash/debris/sediment or blockages.			Remove trash/debris/sediment/blockages and properly dispose.
	Evidence of erosion and bare soil.			Backfill area, seed, mulch and consider matting, E&S measures may be warranted until stabilized.
	Valves, manholes or locks cannot be opened or operated (if present).			Repair/replace any broken fixtures.
	Erosion of outfall channel or riprap deterioration.			Repair and/or supplement riprap outlet protection in accordance with the approved plans.
	Outlets provide inadequate conveyance out of facility.			Repair to properly convey drainage to the outfall per the approved plan. Consult an engineer as needed.
Overall	Access to the facility is in need of repair.			Restore access for maintenance equipment per the approved plans.
	Encroachment on facility or easement by buildings or other structures.			Contact Facilities Planning
	Evidence of oil/chemical accumulation, odor, algae, color or pollution.			Report to management and consult IDDE manual.
	Fences and/or safety signage is inadequate.			Repair fences and signage for public safety.
	Trash in the pool			Remove immediately and observe safety procedures.
	Additional notes:			

BMP Operation & Maintenance Inspection for Manufactured Detention/Filter Structures

Owner Name:	Facility ID # (See Mapping):
Date of Inspection:	As-built plans available: Y N
Date of Last Inspection:	Inspector:
Were issues identified during the previous inspection that required maintenance?	Y N
If so, was the maintenance performed and recorded on a BMP Maintenance Follow-up Form?	Y N
If no, explain:	
Does the current inspection, as summarized hereon, identified maintenance needs?	Y N
If yes, please complete a BMP Maintenance Follow-up Form and provide to the Director of Facilities upon completion.	

BMP Element	Problem	Yes	No	N/A	Corrective Action
Contributing Drainage Area	Excessive trash/debris				Remove trash/debris and properly dispose.
	Bare exposed soil				Stabilize soil with seed and mulch.
	Evidence of erosion				Backfill area, seed, mulch and consider matting. E&S measures may be warranted until stabilized.
	Excessive landscape waste/yard clippings				Remove landscape waste and yard clippings to prevent clogging.
PreTreatment	Excessive trash/debris/sediment				Remove trash/debris and properly dispose.
	Evidence of erosion				Backfill area, seed, mulch and consider matting. E&S measures may be warranted until stabilized.
	Evidence of standing water; ponding, noticeable odors, water stains, presence of algae or floating aquatic vegetation				Sources of possible clogging shall be identified and corrected.
	Dead vegetation, exposed soil				Stabilize according to plans. E&S measures may be warranted until area is stabilized.
Inlets	Inlets provide stable conveyance into system				Make repairs to inlet as required.
	Excessive trash/debris/sediment accumulation at inlet				Remove trash/debris and properly dispose.
	Damage to box structure or grate				Repair minor damage. For major damage contact Manufacturer.
	Evidence of erosion at/around inlet				Sources of erosion shall be identified and controlled when native soil is exposed or erosion channels are
Downspout	Pipe is not delivering conveyances as designed				Remove debris. Damaged pipe shall be repaired.
Chambers	Sediment accumulation threshold has been reached.				Remove sediment and properly dispose.
	Trash and debris have accumulated in				Remove trash/debris and properly dispose.
Filter Media	Stormwater does not percolate uniformly through the planter. Water remains 48 hours after storm.				Filter media may need to be raked, excavated and cleaned, or gravel/soil shall be replaced to correct problem. Holes that are not consistent with the design and allow water to flow directly through the planter to the ground shall be plugged. Sources of possible
	Sediment/debris accumulation is more than 4 inches thick or so thick as to damage or kill vegetation.				Remove by hand with minimum damage to vegetation using proper erosion control measures. Litter and debris shall be removed routinely and upon discovery.
	Mulch is significantly diminished				Add double shredded mulch evenly across the entire unit to a depth of 3"
	Erosion control stones are not correctly placed				Reposition to allow for entry of trash during a storm

Vegetation	Dead vegetation			Replace plant in accordance with approved plans.
	Plant health is poor			Prune as needed, ensure planted well i.e. not leaning or exposed rootzone, check for diseases or pests.
	Vegetative quality of the adjacent grass buffer is poor.			Spot reseed if cover is less than 90%.
	Presence of invasive species/weeds.			Remove by hand with minimum damage to vegetation.
Outlet	Outlets provide inadequate conveyance out of facility			Repair to properly convey drainage to the outfall per the approved plan. Consult an engineer as needed.
	Excessive trash/debris/sediment accumulation at outlet			Remove trash/debris/sediment/blockages and properly dis
	Evidence of erosion at/around outlet			Backfill area, seed, mulch and consider matting, E&S measures may be warranted until stabilized.
Overall	Maintenance access to facility in need of repair			Remove woody vegetation and mow on regular basis.
	Encroachment on facility or easement by buildings or other structures			Contact Facilities Planning
	Additional notes:			

Warning: If any manufactured structure has a watertight cover—be careful regarding the possibility of flammable gasses within the facility. Care should be taken lighting a match or smoking while inspecting facilities that are not vented. If the structure is in a completely enclosed vault the OSHA Confined Space Entry procedures must be followed.

Note: A customized maintenance schedule must be prepared for each manufactured structure, since the maintenance tasks will differ depending on the function. The above is a general guideline only.

BMP Operation & Maintenance Inspection for Vegetated Roof

Owner Name:	Facility ID # (See Mapping):
Date of Inspection:	As-built plans available: Y N
Date of Last Inspection:	Inspector:
Were issues identified during the previous inspection that required maintenance?	Y N
If so, was the maintenance performed and recorded on a BMP Maintenance Follow-up Form?	Y N
If no, explain:	
Does the current inspection, as summarized hereon, identified maintenance needs?	Y N
If yes, please complete a BMP Maintenance Follow-up Form and provide to the Director of Facilities upon completion.	

BMP Element	Problem	Yes	No	N/A	Corrective Action
Vegetation	Plant cover is less than 90%.				Replace dead plantings per the approved plans.
	Debris, vegetative and non, is present.				Remove debris and properly dispose of, including clippings.
	Invasive and nuisance plant species are present.				Completely remove invasive plant species. Weeding shall be manual without the use of herbicides or pesticides.
	Plant bed is dry.				Hand water or use sprinkler system. Follow manufacturers' instructions for O&M. Shade or a water cloth maybe helpful in drought conditions.
Structural Components	Waterproof membrane is leaking or cracked.				Make necessary repairs immediately in accordance with approved plans. Consult engineer as needed.
	Root barrier is perforated.				Repair perforated area.
Drainage Layer/inlet pipes	Drain inlet pipe is in poor condition.				Repair as needed.
	Evidence of ponding, noticeable odors, water stains, presence of algae or floating aquatic vegetation.				Repair cause of standing water in accordance with approved plans. Changes from the approved plans must be reviewed by an engineer. Consult management and the IDDE manual as needed.
	Substrate/medium is not adequate to support healthy plant life.				Consult an engineer or approved plans for the proper media mix specifications and placement guidance for repairs.
	Inflow structures do not provide adequate conveyance to the treatment facility.				Repair structures to drain to facility per plans.
Soil substrate/ growing medium	Deterioration of facility's treatment area or condition.				Repair according to the approved plans, including the dimensions and specified conditions.
	Sediment accumulation.				Remove sediment and properly dispose of.
Overall	Threat of a spill from mechanical equipment or other roof storage items is imminent.				Spill prevention measures for roof systems shall be readily available and used. Correct releases of pollutants immediately in accordance with the IDDE manual.
	Evidence of erosion from wind or water.				Repair erosion and stabilize with additional soil substrate/growth medium and cover with approved plantings.
	Access to the Vegetated roof is unsafe or inefficient.				Restore access. Walkways shall be clear of obstructions and maintained to design standards.
	Evidence of damage or vandalism is present.				Repair as needed.
	Additional notes:				

**BMP Operation & Maintenance Inspection for Manufactured Detention,
Filter & Hydrodynamic Devices**

Owner Name:	Facility ID # (See Mapping):
Date of Inspection:	As-built plans available: Y N
Date of Last Inspection:	Inspector:
Were issues identified during the previous inspection that required maintenance? Y N	
If so, was the maintenance performed and recorded on a BMP Maintenance Follow-up Form? Y N	
If no, explain:	
Does the current inspection, as summarized hereon, identified maintenance needs? Y N	
If yes, please complete a BMP Maintenance Follow-up Form and provide to the Director of Facilities upon completion.	

BMP Element	Problem	Yes	No	N/A	Corrective Action
Contributing Drainage Area	Excessive trash/debris				Remove trash/debris and properly dispose.
	Bare exposed soil				Stabilize soil with seed and mulch.
	Evidence of erosion				Backfill area, seed, mulch and consider matting. E&S measures may be warranted until stabilized.
	Excessive landscape waste/yard clippings				Remove landscape waste and yard clippings to prevent clogging.
PreTreatment	Excessive trash/debris/sediment				Remove trash/debris and properly dispose.
	Evidence of erosion				Backfill area, seed, mulch and consider matting. E&S measures may be warranted until stabilized.
	Evidence of standing water; ponding, noticeable odors, water stains, presence of algae or floating aquatic vegetation				Sources of possible clogging shall be identified and corrected.
	Dead vegetation, exposed soil				Stabilize according to plans. E&S measures may be warranted until area is stabilized.
Inlets	Inlets provide stable conveyance into system				Make repairs to inlet as required.
	Excessive trash/debris/sediment accumulation at inlet				Remove trash/debris and properly dispose.
	Damage to box structure or grate				Repair minor damage. For major damage contact Manufacturer.
	Evidence of erosion at/around inlet				Sources of erosion shall be identified and controlled when native soil is exposed or erosion channels are present.
Downspout	Pipe is not delivering conveyances as designed				Remove debris. Damaged pipe shall be repaired.
Chambers	Sediment accumulation threshold has been reached.				Remove sediment and properly dispose.
	Trash and debris have accumulated in chambers.				Remove trash/debris and properly dispose.

Filter Media	Stormwater does not percolate uniformly through the planter. Water remains 48 hours after storm.			Filter media may need to be raked, excavated and cleaned, or gravel/soil shall be replaced to correct problem. Holes that are not consistent with the design and allow water to flow directly through the planter to the ground shall be plugged. Sources of possible clogging shall be identified and corrected.
	Sediment/debris accumulation is more than 4 inches thick or so thick as to damage or kill vegetation.			Remove by hand with minimum damage to vegetation using proper erosion control measures. Litter and debris shall be removed routinely and upon discovery.
	Mulch is significantly diminished			Add double shredded mulch evenly across the entire unit to a depth of 3"
	Erosion control stones are not correctly placed			Reposition to allow for entry of trash during a storm event.
Vegetation	Dead vegetation			Replace plant in accordance with approved plans.
	Plant health is poor			Prune as needed, ensure planted well i.e. not leaning or exposed rootzone, check for diseases or pests.
	Vegetative quality of the adjacent grass buffer is poor.			Spot reseed if cover is less than 90%.
	Presence of invasive species/weeds.			Remove by hand with minimum damage to vegetation.
Outlet	Outlets provide inadequate conveyance out of facility			Repair to properly convey drainage to the outfall per the approved plan. Consult an engineer as needed.
	Excessive trash/debris/sediment accumulation at outlet			Remove trash/debris/sediment/blockages and properly dispose.
	Evidence of erosion at/around outlet			Backfill area, seed, mulch and consider matting, E&S measures may be warranted until stabilized.
Overall	Maintenance access to facility in need of repair			Remove woody vegetation and mow on regular basis.
	Encroachment on facility or easement by buildings or other structures			Contact Facilities Planning
	Additional notes:			

Warning: If any manufactured structure has a watertight cover—be careful regarding the possibility of flammable gasses within the facility. Care should be taken lighting a match or smoking while inspecting facilities that are not vented. If the structure is in a completely enclosed vault the OSHA Confined Space Entry procedures must be followed.

Note: A customized maintenance schedule must be prepared for each manufactured structure, since the maintenance tasks will differ depending on the function. The above is a general guideline only.

BMP Operation & Maintenance Inspection for Rainwater Harvesting

Owner Name:	Facility ID # (See Mapping):				
Date of Inspection:	As-built plans available:	Y	N		
Date of Last Inspection:	Inspector:				
Were issues identified during the previous inspection that required maintenance?		Y	N		
If so, was the maintenance performed and recorded on a BMP Maintenance Follow-up Form?		Y	N		
If no, explain:					
Does the current inspection, as summarized hereon, identified maintenance needs?		Y	N		
If yes, please complete a BMP Maintenance Follow-up Form and provide to the Director of Facilities upon completion.					
BMP Element					
	Problem	Yes	No	N/A	Corrective Action
Pretreatment	Gutters, downspouts and inflow devices blocked?				Remove all blockages from inflow structures.
	Screens, first flush diverters or vents blocked?				Removal all debris and blockages.
	Vegetation overhanging structures and creating debris/blockages?				Trim all overhanging vegetation to limit the amount of vegetative debris and blockages.
Structural Components	Sediment build up in tank?				Remove sediment and locate source as preventative measure. See above section.
	Structural integrity of the tank, pumps or electrical systems has deteriorated?				Repair in accordance with the approved plans. Consult an engineer as needed.
	Backflow preventer not properly functioning?				Repair in accordance with the approved plans. Consult an engineer as needed.
Outlets	Overflow pipes and paths are not properly functioning?				Restore overflow features per the designed plans. Consult the approved plans and an engineer as needed.
	Outflow spigot blocked?				Remove blockage.
Overall	Additional notes:				

Appendix B: BMP Maintenance Follow-up Form

BMP Maintenance Follow-up FORM

Information from inspection

Campus: _____ BMP ID # (see campus BMP Inventory map): _____

Was the maintenance need generated from an inspection? _____ If yes, date on inspection form: _____

Description of required maintenance: _____

Is maintenance critical to the function of the BMP? Yes No Not sure

Information from maintenance

Individual performing or overseeing maintenance: _____

Requested date for maintenance to be completed by: _____

Date(s) maintenance completed: _____

Did maintenance solve the identified problem? Yes No Not sure

If no or not sure, describe further necessary maintenance and a date for the additional maintenance to be performed:

Description of maintenance performed: _____

Attach photographs to this form and retain for records.